



## **OPERATING AND MAINTENANCE INSTRUCTIONS**

# **ECOLOGICAL GASIFYING BOILER FOR WOOD**

## **ATMOS**

**DC 18 S**

**DC 20 GS**

**DC 25 GS**

**DC 32 GS**

**DC 40 GS**

**DC 22 S**

**DC 25 S**

**DC 32 S**

**DC 50 S**

**DC 40 SE**

**DC 50 SE**

**DC 75 SE**

11/2002

---

**Producer: Jaroslav CANKAŘ - ATMOS**

**Bělá pod Bezdězem**

**Tel.: +420 326 / 701 404, 701 414**

**[www.atmos.cz](http://www.atmos.cz)**

**WE WISH YOU ARE SATISFIED WITH OUR PRODUCT  
AND THEREFORE WE RECOMMEND YOU TO KEEP  
THE BELOW MENTIONED PRINCIPLES THAT ARE  
IMPORTANT FOR THE LONG LIFE AND CORRECT  
FUNCTION OF THE BOILER.**

1. The used wood must be dry – max. 12 - 20 % of moisture – 2 years old.
2. During the gasification process the tars and acid condensates are produced. Therefore it is necessary to install Laddomat 21 behind the boiler in order to keep the temperature of the water returning to the boiler not lower than 65 °C.  
Operating temperature in the boiler should be 80 - 90 °C.
3. If the boiler is fitted with a circulating pump, the running of the pump must be secured via a separate thermostat to ensure the minimal specified temperature of the returning water.
4. The rated boiler capacity ensures its environmental friendly operation.
5. Therefore we recommend the installation of the boiler together with accumulating tanks and Laddomat. This ensures lower fuel consumption (20 – 30 %) and longer durability of boiler and chimney connected with more comfortable boiler attendance.
6. If the boiler is operated at a derated power (water heating in the summer) a daily firing-up is necessary.
7. The checking firing-up and the operational training must be carried out by a professional assembling company.

**CAUTION! If the boiler is fitted with water accumulation tanks and Laddomat 21 (see the enclosed diagrams), the guarantee period of the boiler body is extended from 12 to 36 months. In case of non-observance of these principles the boiler body life and the durability of the ceramics shaped pieces will be reduced because of low-temperature corrosion.**

# 1. Purpose

The ecological warm water boiler ATMOS is determined for heating in the one-family houses and other similar buildings. The boiler types are used according to the required power output from 20 up to 75 kW.

The boilers are constructed especially for combustion of lump wood. All kind of dry wood can be used, especially wood billets with the max. length 330 – 1000 mm according to the boiler type. Also wood blocks with bigger diameter can be used, which reduces the nominal power but prolongs the burning time. The boiler is not suitable for combustion of sawdust and wood waste – these can be used only in small volume – MAX. 10 % - together with wood billets.

The huge fuel hopper will reduce the preparatory operations of the wood, because bigger billets can be used. In this way, the physical effort can be eliminated and the time necessary for fuel cutting saved.

## 2. Technical data see page 3

### Notice

The wood billets with bigger diameter must be divided into halves or quarters (according to the operating demands regarding the nominal power of the boiler). Hard and soft wood can be used.

**The wood must be dry! The power output of the boiler depends on the moisture rate of the wood. The power and the function of the boiler can be secured just if the moisture is 12 - 20 %.**

## 3. Technical description

The boilers are constructed for combustion of wood. The combustion is based on the principle of generator gasification using the exhaust ventilator, which blows the combustion air into the combustion chamber.

The boiler body is a welded drum made of steel plates 3 – 6 mm thick, furthermore a fuel hopper with a fire-resistant shaped piece in the lower part, which has a longitudinal hole for gas and waste gas flow. The combustion chamber below is fitted with ceramic shaped pieces.

In the rear space of the boiler body there is a vertical fuel channel with a firing safety valve in the upper space. The rear part of the main flue is equipped with an exhaust tube connected with the chimney.

The front of the boiler is fitted with a filling door upon an ash pan door.

The firing safety valve pull rod is situated on the upper front of the control panel.

The exterior of the boiler body is insulated with mineral felt placed under the outside metal jacket.

On the boiler top you will find the control panel for the electrical-mechanical control.

At the back, there are the inlet channel for the primary and secondary air with a ventilator and a valve. The primary and secondary air is pre-heated to a high temperature.

### ***The boiler construction gives the following advantages:***

The high temperature combustion with the generator function proceeds in a ceramic combustion chamber with lateral primary air inlet into the boilers GS.

## 2. Technical data

Boiler type	ATMOS						
	DC 18 S	DC 20 GS	DC 25 GS	DC 32 GS	DC 40 GS	DC 50 SE	DC 75 SE
Boiler power output	kW	14-20	17-25	22-32	28-40	35-48	52-75
Heating surface	m	1,8	1,9	2,7	2,9	3,5	5,2
Volumen des Fuel container volume	dm <sup>3</sup>	66	87	130	130	190	252
Specified chimney draught	Pa	16	18	23	23	25	30
Max. water working overpressure	kPa	250	250	250	250	250	250
Boiler weight	kg	293	350	408	415	460	700
Exhaust flue diameter	mm	152	152	152	152	152	180
Boiler high	mm	1120	1200	1200	1200	1300	1420
Boiler width	mm	590	680	680	680	770	770
Boiler depth	mm	845	845	1045	1045	1245	1390
EI. protection class	IP	20	20	20	20	20	20
Power input	W	50	50	50	50	50	70
Boiler efficiency	%						
Max. noise level	dB	65	65	65	65	65	65
Required fuel	dry wood with calorific value 15 – 17 MJ/kg						
Average fuel consumption in season	kg.h <sup>-1</sup>	3,5	3,8	6	7,2	10	18
Max. billet length	mm	330	330	530	530	530	1000
Water volume in the boiler	l	45	64	80	80	90	194
(specified min. temperature of the returning water during the operation: 65 °C)	V/Hz				230/50		
Nominal heating power – waste gas temperature	°C	208	210	225	230	245	240
Nominal heating power – waste gas mass flow	kg/s	0,010	0,012	0,015	0,018	0,021	0,035
Water pressure	mbar	0,18	0,22	0,22	0,22	0,22	0,24
Boiler class		3	3	3	3	3	3
Nominal heating power – wood burning time		2	2	3	2	3	3
Range of adjustment of the thermoregulator	°C				75 – 95		
Dimensions of the filling hole	mm (∅)	450 x 260	(∅) 450 x 260	(∅) 450 x 260	(∅) 450 x 260	(∅) 450 x 260	(∅) 450 x 315
Cool water pressure for the safety heat exchanger	°C/bar				20 > / 2		

# Technical data

Boiler type	DC 22 S	DC 25 S	ATMOS DC 32 S	DC 50 S
Boiler power output	15-22	17-25	24-35	48
Heating surface	2,1	2,3	2,9	4,2
Volumen des Fuel container volume	100	100	140	180
Specified chimney draught	22	23	24	25
Max. water working overpressure	250	250	250	250
Boiler weight	303	306	345	407
Exhaust flue diameter	152	152	152	152
Boiler high	1120	1120	1200	1200
Boiler width	590	590	680	680
Boiler depth	1045	1045	1045	1245
EI. protection class	IP 20	20	20	20
Power input	50	50	50	50
Boiler efficiency	%	80-89	65	65
Max. noise level	65	65	65	65
Required fuel	dry wood with calorific value 15 – 17 MJ/kg			
Average fuel consumption in season	5	6	7,2	13
Max. billet length	530	530	530	730
Water volume in the boiler	58	58	80	89
(specified min. temperature of the returning water during the operation: 65 °C)				
Voltage	230/50	230/50		
Nominal heating power – waste gas temperature	225	225	230	230
Nominal heating power – waste gas mass flow	0,013	0,015	0,018	0,018
Water pressure	0,21	0,21	0,20	0,22
Boiler class	3	3	3	3
Nominal heating power – wood burning time	3	3	3	2
Range of adjustment of the thermoregulator		75 + 95		
Dimensions of the filling hole	(∅) 450 x 260	(∅) 450 x 260	(∅) 450 x 260	(∅) 450 x 260
Cool water pressure for the safety heat exchanger		20 > / 2		

## WASTE GAS EXHAUST VENTILATOR = COMFORTABLE TEMPERATURE

The boiler generator is operated with a pre-heated primary and secondary air. The combustion is characterized through a warm constant flame with constant burning quality.

The big fuel hopper enables to burn the wood billets of max. length 330 – 1000 mm according to the boiler type. large-lump wood waste can also be used.

The boiler is equipped with a cooling loop = security against overheating

## 4. Operating instructions

### Diagramm and control elements of the boiler control panel

#### VARIANT A

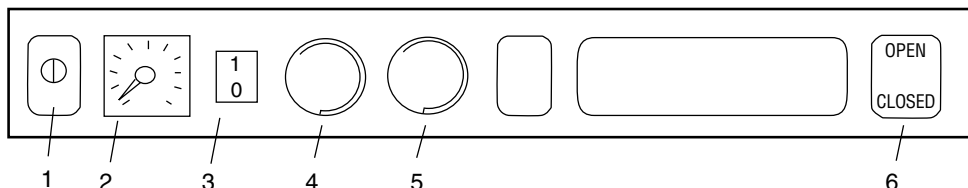

#### VARIANT B

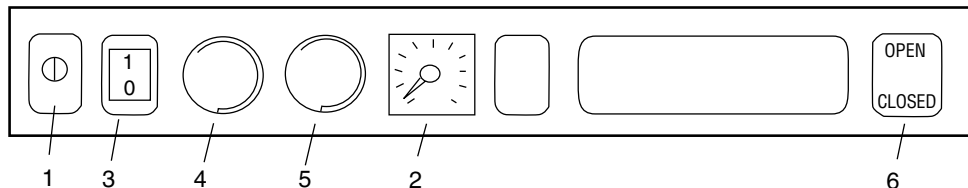

#### Control elements:

- |                               |                                      |
|-------------------------------|--------------------------------------|
| 1. Safety thermostat          | 4. Waste gas thermostat - ventilator |
| 2. Thermometer – outlet water | 5. Operating thermostat - ventilator |
| 3. Master switch – ventilator | 6. Firing safety valve control       |

#### Function of the control elements:

1. The safety thermostat switches off the air distribution of the ventilator after exceeding the temperature 100 °C. For putting the ventilator into operation again the cover must be unscrewed and the button pressed.
2. The thermometer shows the temperature of the outlet water from the boiler.
3. If the boiler is out of operation, the ventilator must be switched off via the master switch.
4. The waste gas thermostat is controlled according to the waste gas temperature in the exhaust flue. It switches the ventilator after the burning out.  
**ATTENTION** – On ignition, set the flue-gas thermostat to “0” °C (ignition). After stabilization of the flame, set the flue-gas thermostat to “operation”. If flue-gas temperature drops below the set value the thermostat will switch off the exhaust fan. If you want the fan to start the flue-gas thermostat should be set to a lower temperature (set to “0” °C - ignition).
5. The operating thermostat switches the ventilator after reaching the outlet water temperature from the boiler. The thermostat must be set at ca. 85-90 °C (mark on the thermostat body).
6. During the boiler operation the firing safety valve must be closed via its pull rod. The pull rod can be pulled out only during the firing-up phase, filling the fuel, removing the ash.

### **Boiler preparation for the operation**

Before putting the boiler into operation it is necessary to check, if the system is filled with water and deaerated.

The boiler must be operated in accordance with these instructions to ensure the quality and the secure function of the boiler. The boilers are allowed to be attended only by adult persons.

During the assembly lay under the rear boiler part to 10 mm.

#### **NOTICE**

During the first firing up a condensation and a condensate outflow appears – it is no default.

In case of combustion of small waste wood the waste gas temperature must be checked – it is not allowed to exceed 320 °C – this can cause a boiler damage.

The appearance of the tars and condensates on the fuel hopper is a normal process that accompanies the wood gasification.

### ***Firing-up and operation***

Before the firing-up the firing safety valve must be opened pulling out the pull rod /17/. Set waste gas thermostat on zero.

Through the upper door /2/ put dry small firewood on the fire resistant shaped pieces /5/ perpendicular to the channel /12/ with a gap 2 - 4 mm between the fuel and the channel because of the flue gases passage. Then paper or woody wool and small firewood again, after this bigger amount of dry wood. After firing-up wait for max. 8 min., then switch on the ventilator /4/ and close the firing safety valve via its pull rod /17/. On the power regulator /22/ set the required warm water temperature. After the firing-up fill the fuel container with wood. Set the thermostat on 100-150 °C (on the point).

For the gasification it is necessary to establish and to keep a reduction zone of glowing charcoal on the ceramic shaped pieces in the fuel container. This condition can be reached burning dry wood of adequate dimensions. If using wet wood, the boiler does not operate as a gasification boiler, the wood consumption is much higher, the required power output cannot be reached and the durability of boiler and chimney will be reduced. The specified draught of the chimney ensures the boiler nominal power 70 % even without a ventilator.

### ***Power regulation – electrical-mechanical***

The power output is controlled with a safety valve /8/ operated with the power regulator FR 124 /22/, which automatically opens or closes the safety valve according to a set output temperature of the water (80 – 90 °C). When setting the power regulator, much attention should be paid to this activity, because the regulator has another function else than power regulation – it also secures the boiler against overheating.

When setting this regulator HONEYWELL type FR 124, the enclosed installation and setting-up instructions should be followed. The protection against overheating and the regulator function should be checked at the water temperature 90 °C. In this stage the regulating safety valve /8/ must be nearly closed. The set point of the power regulator must be checked. The valve position can be seen at the back of the ventilator. A controlling thermostat on the boiler control panel regulates the ventilator according to the set temperature. A temperature on the controlling thermostat is to be set by 5 °C lower than that on the power regulator FR 124. (A point marked on the thermostat scale). The working temperature of water must be checked on a thermometer installed on the control panel.

### ***Filling of wood***

When filling the wood into the fuel container, following steps must be done: first open the valve /13/ with its pull rod /17/ (do not switch off the exhaust ventilator). Wait ca. 10 sec. and then open slowly the filling door /2/ in such a way, that the cumulated gases flow into the gas flue. After this the filling door can be fully opened. The fuel container should be filled completely. To eliminate the smoke escape, the filling up should be performed after the wood is burned out at least to a third. Put a large billet on the glowing charcoal and then fill up normally to minimize immediate burning out and production of the combustion waste products. During the heating the firing safety valve /13/ must be closed – otherwise the ventilator can be damaged.

## Operation with permanent glowing

It is possible to operate the boiler with permanent glowing, it means the fire can be kept during the whole night without firing up every day. In the boiler the burning process can continue for more than 12 hours, therefore it is possible after a filling up of the wood and after switching on the ventilator to reach in a short time the full power output of the boiler again. When operating the boiler with permanent glowing, the water temperature must remain at 80 – 90 °C.

## Cleaning of the boiler

The cleaning of the boiler should be performed regularly and properly in a time interval of 3 – 5 days, because the ash sediments in the fuel container reduce together with tars and condensates the life and power output of the boiler and isolate the heating surface. In case of great volume of ash in the fuel container there is no sufficient space for burning, the holder of the ceramic nozzle and also the whole boiler can be damaged.

Steps: First switch off the ventilator. In case, the boiler is equipped with an exhaust ventilator, this ventilator should run. Open the filling door /2/ and sweep the ash through the hole into the lower chamber. The time interval of the cleaning depends on the wood quality (moisture) and heating intensity, chimney draught (flue) and on other conditions. We recommend to clean the boiler once a week. Do not pull out the fireclay shaped pieces during the cleaning process. For the boiler types DC 20GS, DC 25GS, DC 32GS, DC40GS we offer an additional ash pan, which can be pushed in the lower round space during the cleaning procedure.

### NOTICE:

The regular and proper cleaning is important to ensure the constant power output and long durability of the boiler. In case of insufficient cleaning the boiler can be damaged – the guarantee becomes extinct.

## CERAMIC ASH COLLECTOR

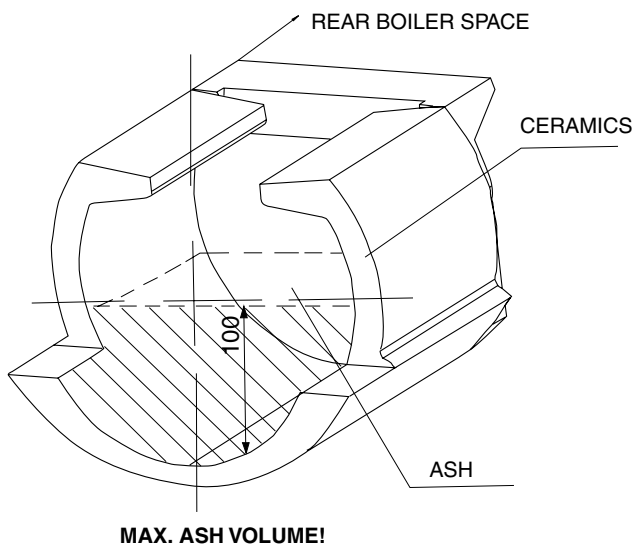

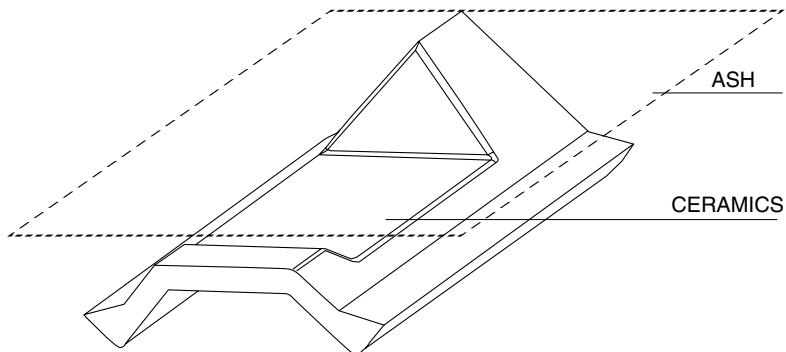

**Maximum amount of ash is up to the level of the roof upper edge!**

## 5. Maintenance of the heating system incl. boiler

The water in the heating system must be checked and if necessary refilled at least once in 14 days. If the boiler is out of operation during the winter, the water in the system could freeze. Therefore it is better to drain the water off or to fill the heating system with an antifreezing solution. The water should be drained off only if necessary and just for a very short time. When the heating season ends, the boiler must be cleaned properly and damaged parts are to be changed.

Twice a year dismantle the ventilator and clean the ventilator runner and the air chamber.

## 6. Fuel

The specified fuel is: dry wood billets and blocks with a diameter between 80 – 150 mm, minimal 2 years old. The moisture 12 - 20 %. The length of the billets should be 330 – 1000 mm and the calorific value 15 – 17 MJ/kg. The fuel dimensions are stated in the article 2 „Technical data“. It is also possible to burn large waste wood pieces together with wood billets.

## 7. Chimney

The connection of the boiler to the chimney flue must be carried out with agreement of an authorized chimney-sweeping firm. The draught of the chimney must be for all operation types sufficient to draw off the combustion gases into the free atmosphere.

It is necessary for the proper boiler function, that the chimney hole has the right dimension, because the combustion, power output and boiler durability depend on the chimney draught. The chimney draught depends directly on the section, height and on the surface roughness of the inside chimney wall. It is not allowed to connect other appliances into the chimney used for the boiler.

The chimney diameter cannot be smaller than the flue hole on the boiler.

Recommended dimensions of the chimney:

20 x 20 cm	min. high 7 m
diameter 20 cm	min. high 8 m
15 x 15 cm	min. high 11 m
diameter 16 cm	min. high 12 m

The exact chimney dimensions are stated in the standard DIN 1056.

The specified chimney draught is stated in the article 2 „Technical data“.

## 8. Boiler accessories

steel brush with accessories	1 piece
feed cock	1 piece
fire hook	1 piece
Operating and maintenance instructions, quality and complete product certificate	1 piece
HONEYWELL Braukmann	1 piece
ash pan	1 piece

## 9. Electrical boiler connection

The electrical boiler connection is carried out with an electric cable with a plug 230 V and 50 Hz. The boiler must be installed near an electrical socket. The electrical boiler connection must be performed according to the valid regulations and standards.

## 10. Choise of the connection of the regulating and control elements

The boiler is delivered with the standard equipment of regulating and control elements. The connection – see the diagram.

We recommend to complete the regulation with other regulating elements (room thermostat, pump) to ensure a comfortable and economical heating system operation. The pump must be connected together with a thermostat in order not to cool the boiler in case of reverse run under 65 °C. The connection of these other elements will be designed by a professional designer according to the specific conditions. The electrical installation if these complementary elements must be carried out by a specialist in accordance with the valid standards DIN.

The basic boiler equipment has a thermostat connected with the pump 70 °C and 90 °C.

For Germany as land of destination is a water shortage protection necessary. This must be installed by the customer/fitter.

## 11. Boiler protection

Using a mixing valve and a thermoregulating valve is a suitable solution of this problem. This enables to create a separate boiler and heating (primary and secondary) circuit. The mixing ration and herewith also the temperature conditions in the boiler and heating circuit are determined by the setting of the mixing valve. The proper adjustment ensures the right mixing of the warm output water from the boiler with the water to be returned so that the temperature of the returning water is over 65 °C. This minimizes the condensation of water vapours, acids and tars in the fuel hopper. The mixing valve enables through its suitable adjustment, that the regulation of the heating water temperature can be carried out independent on the water temperature in the boiler.

As the position of the mixing valve flap and the temperature of the water streaming from the boiler must be continuously regulated according to the requirements of the heating system and according to the changes of room and outdoor temperature, it is necessary to install an electronic regulator.

**The best boiler protection is to connect the boiler with an accumulator and Laddomat.**

**The warranty and after-warranty service is carried out by:**

**ATMOS – Bělá pod Bezdězem**

**Cankář Jaroslav, 294 21 Bělá pod Bezdězem, tel: +420 326/701404**

**fax: +420 326 70 14 92 and by trade representation companies of ATMOS**

## 12. Possible defects and trouble shooting

Defect	Cause	Removal
pilot lamp „network“ does not burn	<ul style="list-style-type: none"> <li>- no voltage in the network</li> <li>- the plug is not pushed in the socket properly</li> <li>- faulty switch</li> <li>- faulty cable</li> </ul>	<ul style="list-style-type: none"> <li>- to check</li> <li>- to check</li> <li>- to change</li> <li>- to change</li> </ul>
The boiler does not reach the required power and set water temperature	<ul style="list-style-type: none"> <li>- few water in the heating system</li> <li>- too strong pump power</li> <li>- the boiler power is not sufficient for the respective warm water system</li> <li>- bad fuel quality (high moisture, billets to big)</li> <li>- leaky firing safety valve</li> <li>- small chimney draught</li> <li>- firing-up process too long or boiler operates with open firing safety valve = vvanes of the exhaust ventilator runner deformed</li> <li>- the boile insufficient cleaned</li> </ul>	<ul style="list-style-type: none"> <li>- to refill</li> <li>- to adjust the pump (thermostat)</li> <li>- design problem</li> <li>- to use dry wood, to cut to billets</li> <li>- to repair</li> <li>- new chimney, the connection is not suitable</li> <li>- to straighten to vanes (angle 90 °)</li> <li>- to clean</li> </ul>
Leaky door	<ul style="list-style-type: none"> <li>- faulty glass packing cord</li> <li>- small chimney draught</li> </ul>	<ul style="list-style-type: none"> <li>- to change</li> <li>- faulty chimney, connection</li> </ul>
Ventilator does not run or is too noisy	<ul style="list-style-type: none"> <li>- disconnection if using a non-reversible safety thermostat type TH 475.1-R105 AS5</li> <li>- the runner is dirty</li> <li>- faulty condenser</li> <li>- faulty motor</li> <li>- bad contact in the plug of the motor supply cable</li> </ul>	<ul style="list-style-type: none"> <li>- to press the bottom on the thermostat</li> <li>- to clean the ventilator, to remove the tars and sediments also from the flue channel</li> <li>- replace</li> <li>- replace</li> <li>- check</li> </ul>

## 13. Fire protection for the installation and use of thermal devices

### *Safety distances*

When installing the boiler, the safety distance from the bulding materials of min. 200 mm must be kept. This distance is valid for the boiler and flue gas ductings that are placed near inflammable materials class B, C1 and C2 (the inflammability classes are stated in the chart 1).

The safety distance (200 mm) must be doubled, if the boiler and the flue gas ductings are installed near inflammable materials class C3 (see chart Nr. 1). The safety distance is also to double if the inflammability class of the materials is not determined.

The safety distance is reduces to a half (100mm) using the thermal insulation plates (asbestos plates) that are incombustible and min. 5 mm thick and are placed 25 mm from the protected inflammable material (fire-proof insulation). A insulating plate or protective screen (on the protected object) must overlap contour of the boiler and flue gas ducting min. 150 mm on each side and min. 300 mm on the upper boiler surface. Also the equipment and facilities made of inflammable materials must be protected with such a plate or screen, if it is not possible to keep the safety distance.

The safety distance must be also kept if storing some facilities near the boiler.

If the boiler is installed on a inflammable floor, an incombustable insulating footplate must be used. This footplate shoul overlap the boiler contour min. 300 mm on the filling door side and min. 100 mm on the other sides. For the thermal insulation the materials class A can be used.

Chart Nr. 1

The inflammability class of building materials and products	Building materials and products according to their inflammability class
A – incombustible	granite, sandstone, concrete, bricks, ceramic tiles, mortar, fire protection plaster
B – uneasy inflammable	akumin, izomin, heraklit, lignos, basalt felt boards, glass fibre boards, novodur
C1 – heavy inflammable	leaf wood (oak, beech), plywood, sirkolit, werzalit, reinforced paper (umakart, ecrona)
C2 – medium inflammable	coniferous wood (pine, larch, spruce), wood chip boards, cork boards, rubber flooring (industrial, Super)
C3 – easy inflammable	wood fibre boards (Hobra, Sololak, Sololit), cellulose materials, polyurethan, polystyrene, polyethylene, expanded PVC

#### **NOTICE**

Under the circumstances that cause temporary higher danger of inflammable gases or vapours production and during work operation that can cause fire or explosion danger (f.e. sticking the floor covering – Linoleum, PVC) the boiler is to put out of operation. It is not allowed to put on the boiler and to stock within the safety distance any objects and things made of inflammable materials.

## 14. Flue gas ducting

The flue gas ducting must be connected to the chimney. If it is not possible to connect the boiler with the chimney directly, the flue tube should be as short as possible, not longer than 1 m, without any additional heating surface, and it must rise in the chimney direction. The flue gas ductings must have mechanical strength, must be leak-proof against the combustion products and clean inside. The flue gas ductings are not allowed to lead through the somebody else's flats or utility rooms.

The inside diameter of the flue gas ducting must not be bigger than the inside diameter of the chimney flue and must narrow to the chimney. The use of elbows is not suitable.

## 15. Boiler environment

The boiler must be installed in a boiler room with sufficient air supply needed for the combustion. The installation of the boiler in the habitable room inc. corridors is not acceptable.

## 16. Attendance and inspection

The boiler attendance is to be performed according to the operating and maintenance instructions. It is not allowed to carry out such interventions that might threaten somebody's health.

Only person over 18 years are allowed to attend the boiler.

It is not permitted to let children alone near an operating boiler.

When operating the boiler for solid fuel, it is forbidden to use inflammable liquids for firing-up. Furthermore it is not allowed to increase the nominal power of the boiler during its operation (overheating).

It is not permitted to put inflammable objects on the boiler and near the filling door and the ash pan holes. The ash must be stored in incombustible containers with a cover.

The operating boiler must be controlled from time to time.

The user may perform only such repairs that contains just simple exchange of delivered spare parts (for example ceramic shaped pieces, packing cord). During the boiler operation the leak-proofness of the doors and cleaning holes must be checked incl. proper tightening. The user is not allowed to make any intervention into the construction and electric installation of the boiler. The boiler must be cleaned always proper and in time to ensure the passage capacity of all channels and flue gas ductings. The filling door and ash pan door must be always closed properly.

## 17. Binding standards for the boiler design and installation

DIN EN 303-5

DIN 4705

DIN 18160

DIN 4751-1

DIN 4741-2

DIN 4701

ONORM M 7550

**The mixing fittings of Laddomat 21 a necessary element for the regulation of the central heating. This ensures, that the temperature of the water returning to the boiler is not lower than 65 °C, which prolongs the durability of boiler and chimney and reduces the production of tars in the boiler. The boiler should be operated at a operating temperature not under 80 °C, otherwise the boiler life will be reduced - 2 years shorter durability.**

**The recommended temperature is between 80 – 90 °C.**

Considering the power output of the boiler we recommend to add 10 % for the potential lower fuel quality and higher moisture.

The boiler must be installed in such a way, that in case of a fall-out of electrical energy the boiler is protected against overheating, otherwise the boiler might be damaged. To ensure the max. durability of the boiler and chimney and the minimum of exhalations we recommend an installation with accumulating tanks and Laddomat.

## 18. Spare parts

Fire resistant shaped piece – nozzle	5
Fire resistant shaped piece	10, 12, 14, 9
Ventilator	4
Switch with pilot lamp	20
Thermometer	18
Thermostat	24
Packing cord for the door 18 x 18	26
Safety thermostat	7
Nozzle sealing	11
Flue gas thermostat	27
Pump thermostat (70 °C)	28
Pump thermostat (90 °C)	29

### ***Replacement of the fire resistant shaped piece (nozzle)***

Material list:

1. fire resistant shaped piece
2. packing cord
3. boiler cement

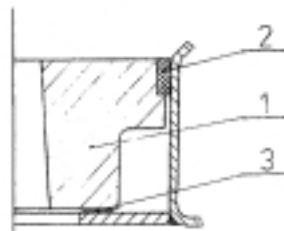

**Procedure:** Take out the resistant shaped piece (farther only nozzle) or smash it to pieces. Clean the nozzle holder properly to remove the tar and old cement. Make thinline of the boiler cement and put them on the nozzle holder round the hole so that the secondary air can not flow through the nozzle. Take the nozzle in the hand, stand in front of the boiler, rotate the nozzle in the following orientation: the hollow must be farther from you and at the bottom /the hollow is orientated inside the boiler, the nozzle mark – if there is any – at the back). In the rear boiler space the secondary air is conducted into the nozzle. Put the nozzle on the holder so that the clearance between the nozzle and the holder all over constant is. Take the packing cord and form it by means of a hammer to a square or rectangle. Put the cord round the nozzle (with narrow edge at the bottom) and bring it flush with the nozzle by slow, even hammering.

### ***Replacement of the door packing cord***

Procedure: take out the old cord by means with a screwdriver, clean the groove (slot). Form the packing cord by means of a hammer to a square or rectangle Take the cord and press it round the door panel (with narrow edge into the groove) and fix it (you can used the hammer). Take the door handle, put it up and press the cord into the groove by slow slamming the door untill it is possible to close it. Only this process can ensure the proper tightness od the door.

## Door hinges and door closing

The filling door and the ash pan door are firmly connected with the boiler by means of two hinges. A hinge contains a nut that is welded on the boiler body, adjusting screw and a pin for fixing the door. If you wish to change the position of the hinges, first you must unlock and open the upper boiler cover (control panel), take both pins out, take the door off and turn the adjusting screw according to need. Inverse process brings all into the original arrangement.

The door closing has a lever with a handle and a cam, which operates the wheel screwed in the boiler, and a safety nut that prevent from the rotation. After some time the packing cord in the door panel will be squeezed so that the wheel must be screwed in more firmly. Loose the wheel nut and screw the wheel into the boiler in that way, that the handle shows after closing the door on an imaginary clock 20 minutes.

## 19. Basic data concerning the wood combustion

We recommend to burn mostly dry wood. You can reach the maximal power output and boiler durability if burning min. 2 years old wood.

The following diagram shows the dependance of the water content on the fuel caloric value. This value falls considerably with the increasing water content.

Example:

Wood with water content 20 % has the caloric value 4 kWh/ 1 kg wood

Wood with water content 60 % has the caloric value 1,5 kWh/ 1 kg wood

### • Spruce wood after 1 year of shed storage

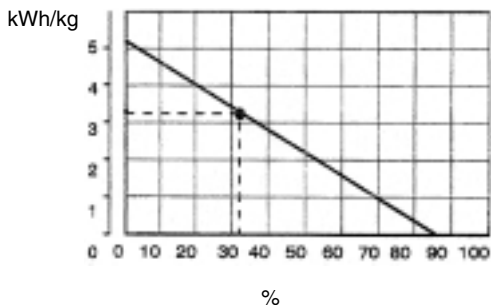

### Max. boiler power output if using this fuel:

- DC 18 S - 13 kW
- DC 20 GS - 14 kW
- DC 25 GS - 19 kW
- DC 32 GS - 24 kW
- DC 40 GS - 31 kW
- DC 50 S - 39 kW
- DC 75 S - 54 kW

wood	caloric value 1 kg		
	kcal	kJoule	kWh
spruce	3900	16250	4,5
pine	3800	15800	4,4
birch	3750	15500	4,3
oak	3600	15100	4,2
beech	3450	14400	4,0

Fresh wood has a low caloric value, does not burn good, produces smoke and reduces the durability of the boiler and the chimney. The power output of the boiler will decrease to 50 % and the fuel consumption will increase to the double volume.

## Legend to the boiler diagram

- |   |  |
|---|--|
| 1. Boiler body  | 15. Cleaning cover                     |
| 2. Filling door                                       | 16. Orifice plate – DC 18 S            |
| 3. Ash pan door                                       | 17. Firing safety valve pull rod       |
| 4. Ventilator – pressure, exhaust                     | 18. Thermometer                        |
| 5. Fire resistant shaped piece – nozzle               | 19. Furnace orifice plate              |
| 6. Control panel                                      | 20. Switch                             |
| 7. Safety thermostat                                  | 22. Power regulator – Honeywell FR 124 |
| 8. Regulating safety valve                            | 23. Cooling loop                       |
| 9. Fire resistant shaped piece – furnace side         | 24. Ventilator thermostat              |
| 10. Fire resistant shaped piece – round<br>space      | 25. Door panel – Sibrál                |
| 11. Sealing – nozzle 12 x 12                          | 26. Door sealing – cord 18 x 18        |
| 12. Fire resistant shaped piece - half-moon           | 27. Waste gases thermostat             |
| 13. Firing safety valve                               | 28. Pump thermostat 70 °C              |
| 14. Fire resistant shaped piece – rear round<br>space | 29. Pump thermostat 90 °C              |
|   | 30. Shaped piece (roof)                |

## MODELLS 2002 - BOILER WITH EXHAUST VENTILATOR

Typ ATMOS	DC 18 S	DC 20 GS	DC 32 GS	DC 25 GS	DC 40 GS	DC 40 SE	DC 50 SE	DC 75 SE	DC 22 S	DC 25 S	DC 32 S	DC 50 S
A	1120	1200	1200	1200	1350	1300	1300	1420	1120	1120	1200	1200
B	690	690	890	890	890	890	1090	1390	890	890	890	890
C	590	670	670	670	670	770	770	770	590	590	670	670
D	872	946	946	946	1092	1046	1046	1153	872	872	946	1090
E	152	152	152	152	152	152	152	180	152	152	152	152
F	65	75	75	75	75	70	70	75	65	65	75	75
G	200	180	180	180	180	180	180	180	200	200	180	180
H	930	1000	1000	1000	1137	1100	1100	1100	930	930	1000	1000
CH	220	255	255	255	255	305	305	305	220	220	255	255
I	190	240	240	240	240	290	290	290	190	190	240	240
J	6/4"	6/4"	6/4"	6/4"	2"	2"	2"	2"	6/4"	6/4"	6/4"	2"

## BOILER WITH EXHAUST VENTILATOR (S)

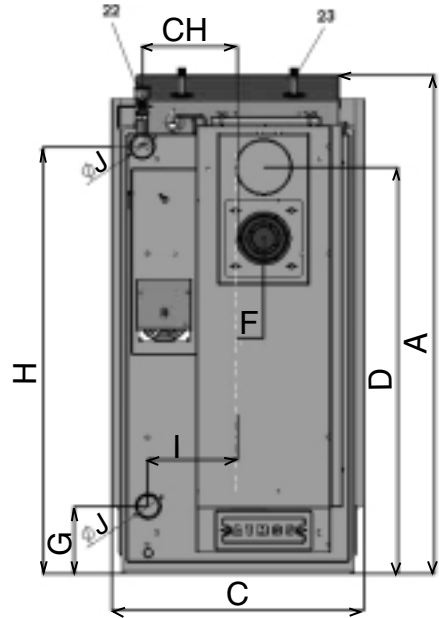
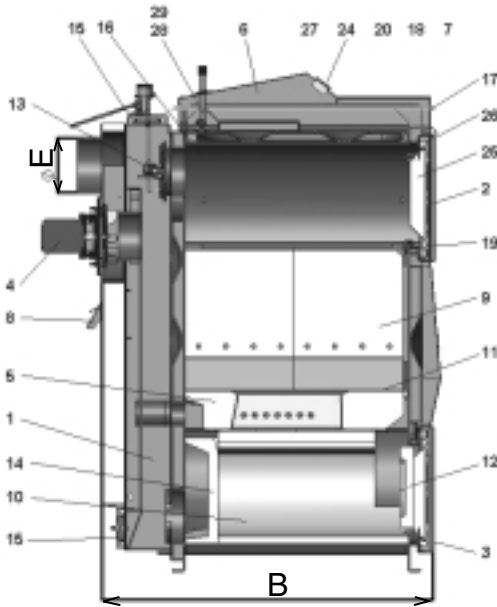

ATMOS  
 DC 18 S, DC 22 S, DC 25 S, DC 32 S,  
 DC 40 SE, DC 50 S, DC 50 SE, DC 75 SE

ATMOS GENERATOR  
 DC 20 GS, DC 25 GS, DC 32 GS, DC 40 GS

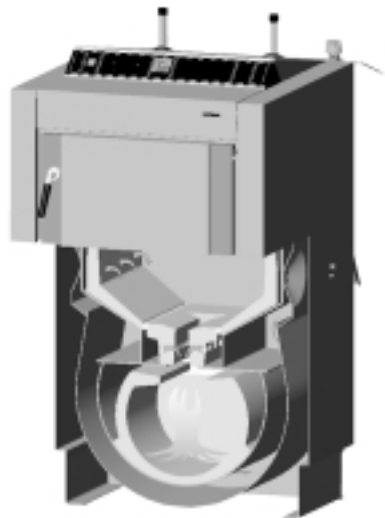
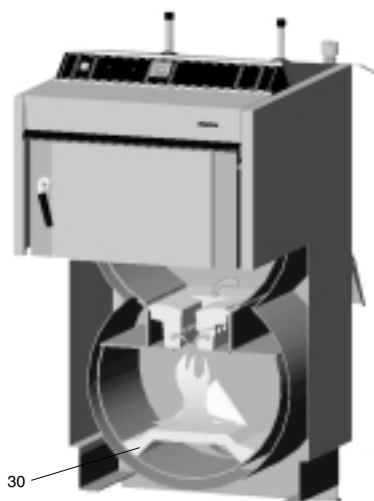

## **Type and installation of shaped pieces into the combustion chamber**

### **1. For the type:**

DC 22 S  
DC 25 S  
DC 32 S  
DC 50 S  
DC 40 SE  
DC 50 SE

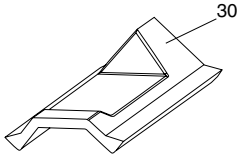

Shaped piece (roof) of the bottom combustion chamber should always be pushed back against the boiler rear wall.

### **27. Ceramics - roof.**

(DC 22S, DC 25S, DC 32S, DC 40SE - 500 mm)  
(DC 50S, DC50 SE - 700 mm)

### **2. For the type:**

DC 75 SE

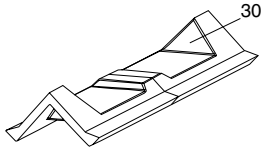

The roof is composed of two pieces – see the figure.  
(DC 75SE - 2 x 500 mm)

### **3. For the type:**

DC 18 S  
DC 20 GS  
DC 25 GS  
DC 32 GS  
DC 40 GS

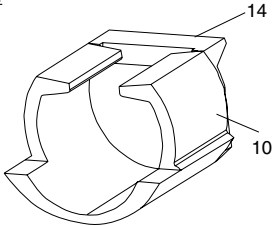

Shaped piece (spherical space) should be assembled in such a way that the front part of the shaped piece (10) is 3 cm from the front edge of the boiler frame.

10. Ceramics – spherical space (L + R)

14. Ceramics – rear face

**(Attention – during possible handling do not turn the rear face)**

DC 40 SE  
DC 50 SE  
DC 75 SE

In certain cases there boilers can also be fitted with a spherical space instead of the roof.

## HONEYWELL Braukmann

### Heating power regulator FR 124 Installation instructions

Disassemble the lever (1)  
and the joint (2).

### Adjustment

Heat the boiler to the temperature ca. 80 °C. Set the regulating lever at the temperature which you can read on the boiler thermometer. In case of vertical installation the white marking and white numbers are valid.

### Adjustment of the primary and secondary air proportion

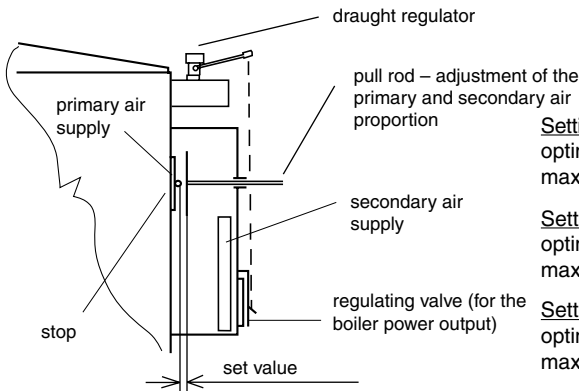

Setting for the boilers DC 18 S - DC 40 SE (GS)  
optimum: to the stop (5 mm) + 6÷10 mm  
maximum: to the stop (5 mm) + 10÷12 mm

Setting for the boilers DC 50 SE  
optimum: to the stop (12 mm) + 6÷10 mm  
maximum: to the stop (12 mm) + 10÷12 mm

Setting for the boilers DC 75 SE  
optimum: to the stop (20 mm) + 6÷10 mm  
maximum: to the stop (20 mm) + 10÷12 mm

Set the regulating lever at the temperature which you can read on the boiler thermometer.

### Diagram of the exhaust ventilator

- 1 – motor
- 2 – plate
- 3 – runner
- 4 – nut the left-hand thread and washer
- 5 – wing nut
- 6 – screw
- 7 – large seal
- 8 – small seal

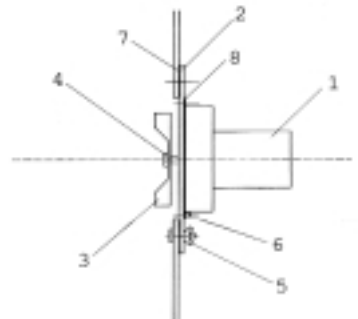

**CAUTION!** The exhaust ventilator is delivered in dismantled state. Put it on the rear smoke flue, tighten properly, connect to the socket and check its smooth running.



# Installation Diagram mechanical regulation with exhaust ventilator, Type UCJ 4C52, UCJ 4C82 (DC 18 S - DC 75 SE) (DC 20 GS - DC 40 GS) Variant A

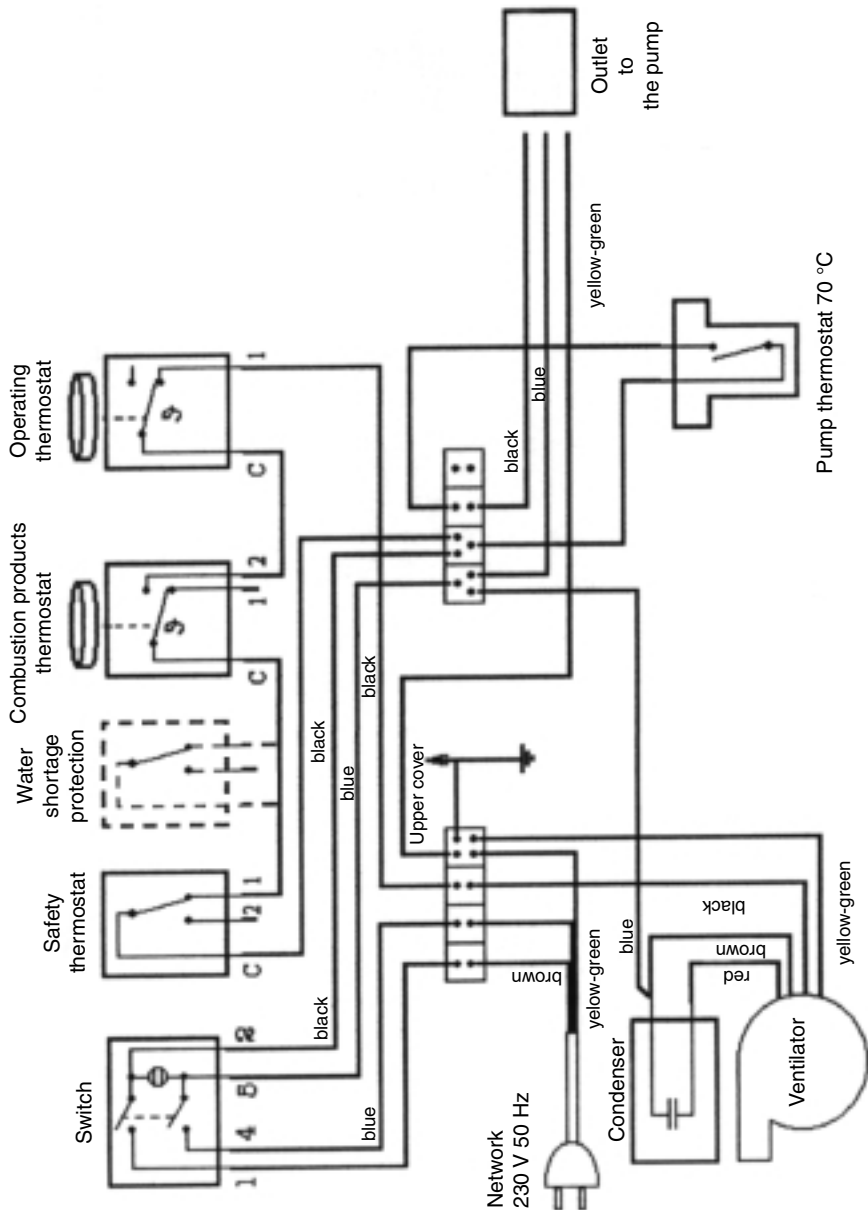

The boiler has a combustion products thermostat and a pump thermostat 70 °C.

# Installation Diagram mechanical regulation with exhaust ventilator, Type UCJ 4C52, UCJ 4C82 (DC 18 S - DC 75 SE) (DC 20 GS - DC 40 GS) Variant B

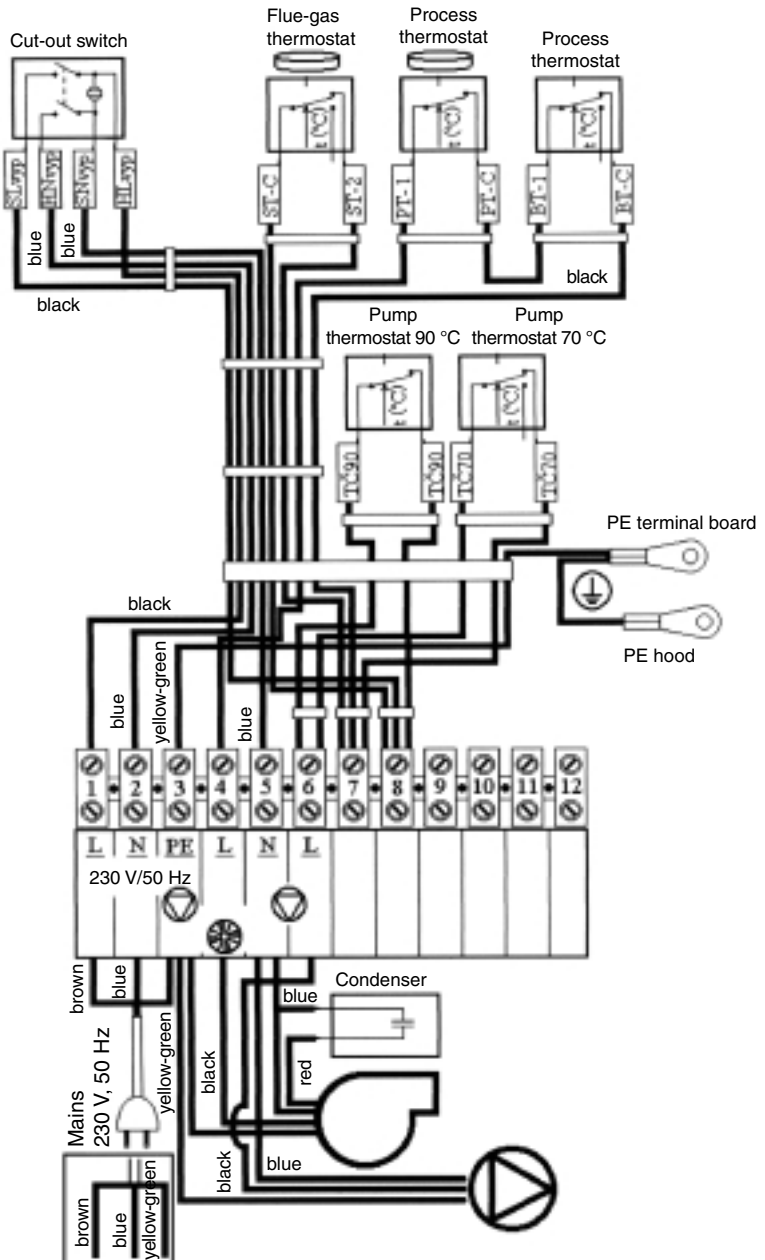

## Installation diagram with LADDOMAT 21 and Accumulating tanks

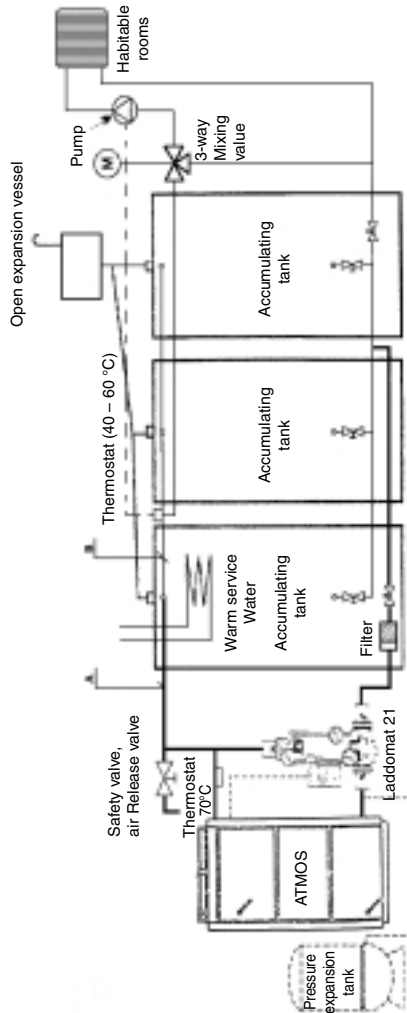

### Tubeing diameter for Installation with Accumulating tanks

Power output of Boiler	Part A		Part B	
	Copper	Steel	Copper	Steel
18 - 25 kW	28x1	25(1")	28x1	25(1")
30 - 40 kW	35x1,5	32(5/4")	28x1	25(1")
50 - 75 kW	42x1,5	40(6/4")	35x1,5	32(5/4")

## BOILER PROTECTION AGAINST OVERHEATING

Boiler is fitted with a cooling exchanger and with a safety valve Honeywell TS 130-3/4A  
(The temperature 95 °C opens the valve)

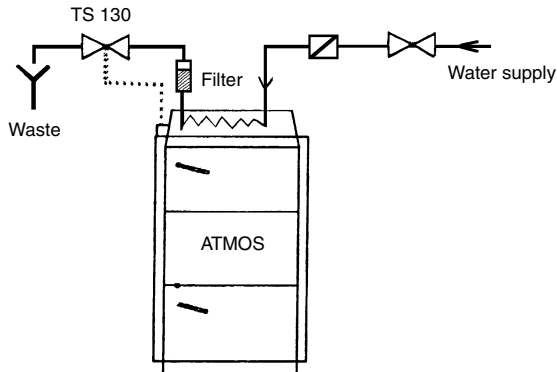

The safety valve TS 130 has a sensor placed on the boiler back, protects the boiler against overheating: if the temperature in the boiler exceeds 95 °C, the water is supplied through the water inlet pipe into the cooling loop – the water absorbs the excessive energy and then it flows off into the canalization.

### ***System operation with accumulating tanks***

After firing up the boiler, it is operating at full power output (2 – 4 fillings) until the accumulating tanks are completely at a temperature of 90 – 100°C. Then let consume all the fuel. Subsequently, the heat in the accumulating tanks is consumed via a 3-way mixing valve. The time of this consumption depends on the total volume of the accumulating tanks and on the out-door temperature. In the heating season (taking the minimum accumulating tanks volume into consideration), this period may be 1 – 3 days. If using accumulation, we recommend min. 1 vessel (500 l) as expansion tank. It is used for boiler power balancing.

### ***Tank insulation***

A good solution is to insulate all the accumulating tanks, up to the number necessary for obtaining the required volume, into one unit, with mineral wool on a frame of gypsum desks. Additionally, loose insulation material can be used. Minimum recommended thickness of mineral wool insulation is 120 mm. Another alternative is an insulation of separate tanks with polyurethane or mineral wool and ST-foil in an artificial leather case.

# Laddomat 21

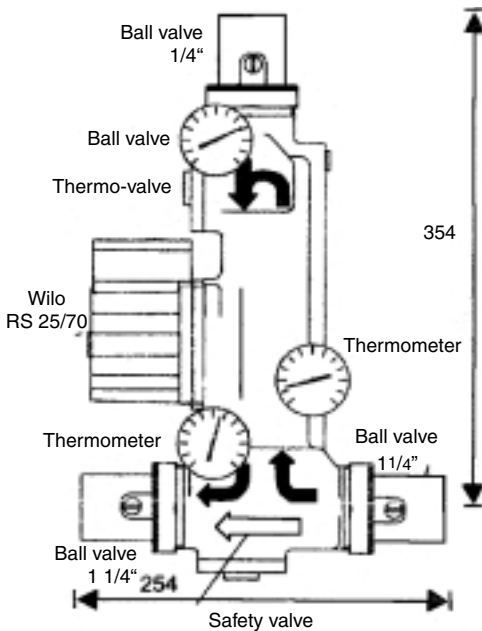

Laddomat 21 replaces with its construction the normal installation of individual parts. It consists of a cast iron body, a thermoregulating valve, a pump, a safety valve, ball valves and thermometers, when the temperature of water in the boiler is 78 °C, the thermoregulating valve opens an inlet from a container. The connection using the Laddomat 21 is much easier, therefore we recommend it to you.

A spare thermo-cartridge for a temperature of 72 °C is supplied with the Laddomat 21 armature. Use it for boiler over 32 kW. Laddomat 21 is intended for the output of max. 75 kW.

## Advantages:

- The installation of the boiler with accumulating tanks result in a number of advantages:
- lower fuel consumption (20 – 30 %), the boiler operates at full power output and maximum efficiency, until the fuel has burned out
  - longer durability of boiler and chimney – production of tars and acids is minimized
  - combination with other ways of heating is possible – e.g. electricity for heat accumulation
  - combination of radiators with floor heating
  - comfortable heating and perfect burning out of the fuel
  - more ecological heating

OPERATING DATA	
max. operating pressure	0,25 MPa
calculated overpressure	0,25 MPa
testing overpressure	0,33 MPa
max. operating temperature	100 °C

MINIMUM ACCUMULATING TANK VOLUME						
power output/KW	20	25	32	40	49	75
Volume/l	1000-2000	1500-2000	2000-2500	2500-3000	3000-4000	4000-5000

# WARRANTY CERTIFICATE

for warm water boiler

type: ..... series/production year: .....

date of sale: .....

dealer's stamp: .....

## Unfilled warranty certificate is invalid

### Warranty conditions:

1. If observing the purpose of use, operating and maintenance conditions stated in this instructions, we warrant, that the product will keep the qualities complying with the technical standards and conditions for the whole warranty period, it means 12 months since the date of the taking over of the product by the customer and max. 20 months since the product has been sold by the producer to the dealer. If the installation is carried out by a specialist, the warranty for the boiler body is 3 years, for other parts 1 year.
2. If a defect appears during the warranty period, that wasn't caused by the user, the product will be repaired free of charge.
3. The warranty period extended according to the time during which the product have been in the warranty repair.
4. The customer claims the warranty repair need during the warranty period in a service repair shop.
5. The service repair shop is obliged to remove the functional defects claimed by the customer free of charge and in determinated time.
6. The buyer has been acquainted with the boiler use and operating.
7. The customer claims the after-warranty repairs also in a service repair shop. In this case, however, the customer pais the repairs costs himself.
8. The user is obliged to follow this operating and maintenance instruction. The warranty becomes extinct, if these instructions are not followed, if the boiler is operated with negligence or unprofessional handling or if an unapproved fuel is burned. In that case, all repair costs are to be paid by the user.
9. The boiler must be checked incl. the setting of the control and structural elements by a professional company min. once a year. This inspection must be notices and confirmed in this warranty certificate.

# CERTIFICATION

ABOUT THE QUALITY AND COMPLETENESS OF THE PRODUCT

The warm water boiler, prod. number:..... was checked before shipping.

The product complies with the required quality and is complete according to the enclosed product documentation. The product is in conformity with the standard EN 303-5 and LGBL Nr. 33/1992.

Prepared for shipping on:

Final test:

Date:

Date:

The installation carried out by:

Date:

## Records on carried out guarantee and post-guarantee repairs

Repair: .....

.....

.....

.....

.....

.....  
Carried out by, date

Repair: .....

.....

.....

.....

.....

.....  
Carried out by, date

Repair: .....

.....

.....

.....

.....

.....  
Carried out by, date

Repair: .....

.....

.....

.....

.....

.....  
Carried out by, date

Repair: .....

.....

.....

.....

.....

.....  
Carried out by, date

## CONTENT

1. Purpose	2
2. Technical data	3
3. Technical description	3
4. Operating instructions	5
- Boiler preparation for the operation	5
- Firing-up and operation	6
- Power regulation - electrical -mechanical	6
- Filling of wood	6
- Operation with permanent glowing	7
- Cleaning of the boiler	7
- Ceramic ash Collector	7
5. Maintenance of the heating system incl. boiler	8
6. Fuel	8
7. Chimney	8
8. Boiler accessories	9
9. Electrical boiler connection	9
10. Choise of the connection of the regulating and control elements	9
11. Boiler protection	9
12. Possible defects and trouble shooting	10
13. Fire protection for the installation and use of thermal devices	10
- Safety distances	10
14. Flue gas ducting	12
15. Boiler environment	12
16. Attendance and inspection	12
17. Binding standards for the boiler design and installation	12
18. Spare parts	13
- Replacement of the fire resistant shaped piece (nozzie)	13
- Replacement of the door packing cord	13
- Door hinges and door closing	14
19. Basic data concerning the wood combustion	14
- Legend to the boiler diagram	15
- Boiler with exhaust Ventilator (S)	16
- Type and installation of shaped pieces into the combustion chamber	17
- Honeywell Braukmann	18
- Adjustment of the primary and secondary air proportion	18
- Diagram of the exhaust ventilator	18
- Installation Diagram mechanical regulation with exhaust ventilator - Variant A	19
- Installation Diagram mechanical regulation with exhaust ventilator - Variant B	20
- Installation Diagram with LADDOMAT 21 and Accumulating tanks	21
- Boiler protection against overheating	22
- System operation with accumulating tanks	22
- Tank insulation	22
- Laddomat 21	23
- Warranty certificate	24
- Certification about the Quality and Completeness of the Product	25
- Records on carried out guarantee and post-guarantee repairs	26

Comments: